

# EWL

- Zone 1, 2, 21, 22
- Replaces traditional discharge lamps of up to 750W
- Saves in energy, maintenance and installation costs
- Instant, bright illumination
- Suitable for GAS category IIC
- 5 years warranty

**'Ex op is'**  
safe optical radiation



# EWL Series High bay LED lighting fixture

EWL series LED High Bay lighting fixture combines a light and compact design with improved performance and reliability over time in terms of safety, efficiency and energy saving guaranteeing a lifespan of 20 years of constant high quality illumination. The EWL series is suitable for installation at low and medium heights in all those areas defined as hazardous due to the presence of gases and explosive dusts such as Zones 1, 2, 21 and 22. The universal steel mounting bracket complies with all application requirements. Unlike the rest of the market that offers a modification of LEDs inside old lighting fixtures, the EWL series has been specifically designed to meet the technical requirements of LEDs. In effect, the body of the lamp acts as a heat dissipater for the LED plate meaning that more powerful lighting can be installed without causing any deterioration of the actual LEDs. The protective shockproof glass plate is resistant to high temperatures and ensures that light emissions do not pollute the surrounding environment. The LED board is positioned in a separate "chamber" housing the electronic power supply system and this in turn is separated by an "Ex e" terminal box housing that is used to connect the lighting fixture to the electronic power supply system through a cable gland with an Ex (non barrier)

O-ring as specified in EN/IEC 60079-14. The fact that discharge lamps containing mercury are not used in hazardous areas makes these light fixtures eco-compatible and they have a no cost environmental impact in the event of recycling. LED lights can be fitted with a lens that changes their photometric properties meaning that the same lamp body can replace a traditional discharge lamp lighting fixture (EV, EW, EWA series). A further advantage in using EWL series LED fixtures lies in the knowledge that the degree of illumination will never just fade. If one LED fails, the others keep on working and when the lamp is turned on, the light reaches its maximum level instantly.

## Application sectors:



## CERTIFICATION DATA

<b>Classification:</b>	Group II	Category 2GD		
<b>Installation:</b> EN 60079.14	zone 1 - zone 2 (Gas)	zone 21 - zone 22 (Dust)		
<b>Marking:</b>	CE 0722 Ex II 2GD Ex db eb op is IIC T.. Gb - Ex tb IIIC T.. °C Db IP66			
<b>Certification:</b>	ATEX CML 16 ATEX 1348			
	IEC Ex CML 16.0118	All IEC Ex, TR CU and INMETRO certification data can be downloaded at <a href="http://www.cortemgroup.com">www.cortemgroup.com</a>		
	TR CU <u>DISPONIBLE</u>			
	INMETRO DNV 14.0153			
<b>Standards:</b>	CENELEC EN 60079-0: 2012 A11 COR1: 2013, EN 60079-1: 2014, EN 60079-7: 2015, EN 60079-31: 2014, EN 60079-28: 2015 and EUROPEAN DIRECTIVE 2014/34/UE IEC 60079-0: 2011, IEC 60079-1: 2014-06, IEC 60079-28: 2015, IEC 60079-31: 2013, IEC 60079-7: 2015 European Directive 2004/108 Electromagnetic compatibility European Directive 2012/19/UE, 2002/96/CE, 2003/108/CE WEEE European Directive 2011/65/UE RoHS			
<b>Class temperature:</b>	85°C (T6)	100°C (T5)		
<b>Ambient temperature:</b>	-40°C +60°C Standard	-20°C +60°C (EWL-80/EWL-801)	-40°C +60°C (EWL-80C/EWL-801C)	
<b>Degree of protection:</b>	IP66			

# EWL Series High bay LED lighting fixture

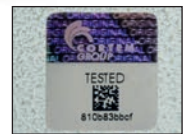

**ORIGINAL PRODUCT**

## MECHANICAL FEATURES

- Body:** Low copper content aluminium alloy fitted with cooling fins for better heat dissipation
- Glass face:** Shock and temperature resistant tempered glass sealed with aluminium ring
- Gaskets:** Acid, hydrocarbon and high temperature resistant silicone
- Supporting bracket:** Stainless steel AISI 316L
- Bolts and screws:** Stainless steel
- Entries:** 2 x ISO M20 entries. Fixture kit with PLG11B plug and NAV20SIB cable gland
- Coating:** Polyester coating Ral 7035 (Light grey)

**Corrosion Resistance:** The STANDARD of the aluminium alloy used by Cortem has passed the tests required by standards EN60068-2-30 (hot/humid cycles) and EN60068-2-11 (salt mist tests)

## EXPLODED DIAGRAM OF EWL-80 LIGHTING FIXTURE

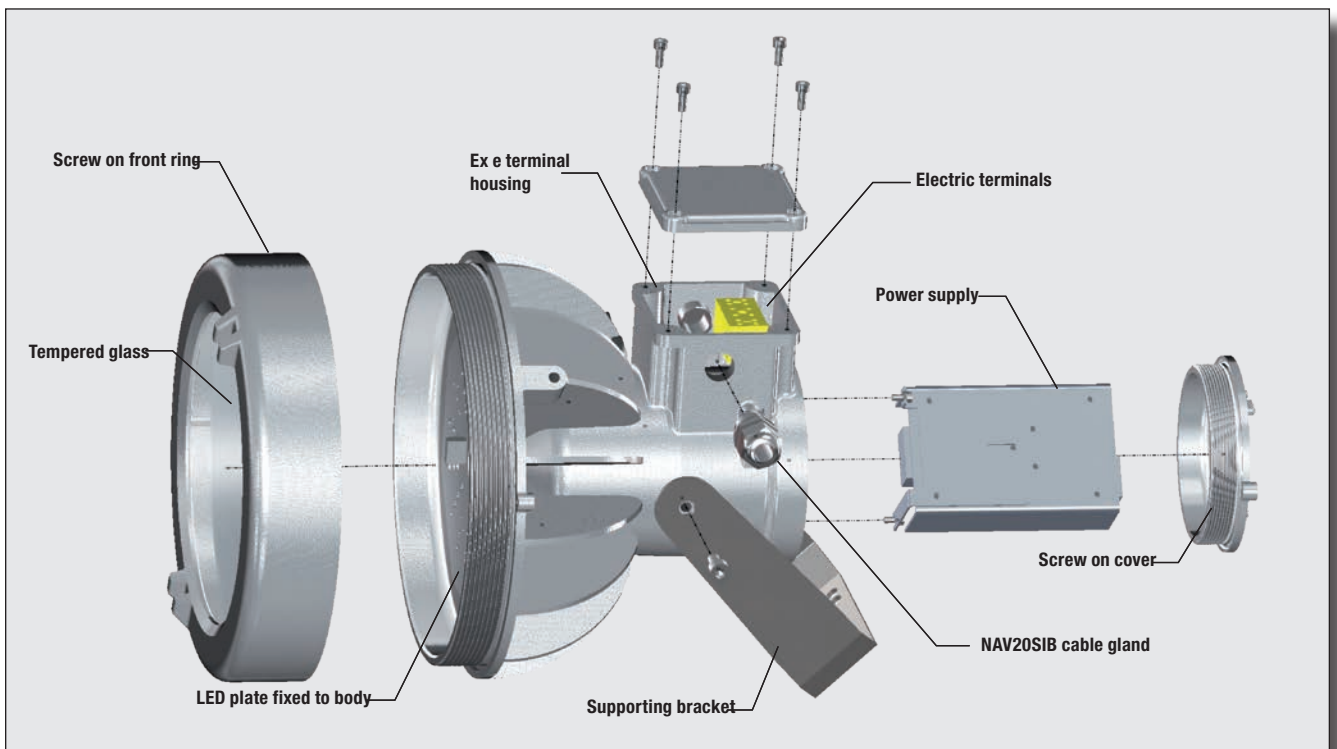

## EWL Series High bay LED lighting fixture

Electrical features	EWL-70	EWL-80 EWL-80C	EWL-801 EWL-801C	EWL-100	EWL-1001
Power supply:	220-240 Vac ±10%	100-277 Vac ±10% (24 Vdc <b>EWL-80/24</b> ) (48 Vdc <b>EWL-80/48</b> )	220-240 Vac ±10%	100-277 Vac ±10% (24 Vdc <b>EWL-100/24</b> ) (48 Vdc <b>EWL-100/48</b> )	100-277 Vac ±10%
Rated frequency:	50-60 Hz ±5%	50-60 Hz ±5%	50-60 Hz ±5%	50-60 Hz ±5%	50-60 Hz ±5%
Power consumption:	40 W *	55 W *	110 W *	188 W * (183 W a 12,24,48 Vdc)	177 W *
Connection:	Direct connection to terminal board L, N, Pe. Section 4mm <sup>2</sup> , suitable for loop-in/loop-out				
Power factor:	>0,95 *	>0,95 *	>0,95 *	>0,95 *	>0,95 * >0,96
Rated current:	185 mA *	260 mA *	508 mA *	850 mA *	800 mA*
Initial current:	1,55 A	2 A	-	2,70 A	-
Initial current/Rated current:	8	8	-	3	-
EMC: (electromagnetic compatibility)	EN 55015, EN 61547, IEC 61000-3-2, IEC 61000-3-3, IEC 61000-4-...				
THD: (total harmonic distortion)	<15% 100-240 Vac				
Over-voltage protection:	2 kV	2 kV	6 kV	2 kV	2 kV
Driver performances:	Over-Voltage protection, Over-Current protection, Short-Circuit protection				
Dimmer (on request):	(0-10 V)	(0-10 V)	(0-10 V)	(0-10 V) or PWM or resistor	(0-10 V) or PWM or resistor
<b>Photometric features</b>					
LED:	Cree XTE	Cree XTE	Cree XTE	Cree XTE	Cree XPL
Viewing angle:	120°	120°	120°	120°	120°
Type:	Cool White	Cool White	Cool White	Cool White	Cool White
Group::	R4	R4	R4	R4	R4
Colour temperature:	5700 K	5700 K	5700 K	5700 K	5700 K
CRI:	>70	>70	>70	>70	>70
Instant Restrike:	YES	YES	YES	YES	YES
L80:	> 60500	> 60500	> 60500	> 60500	> 72600
<b>Lumen:</b>	<b>3700 lm</b>	<b>6050 lm</b>	<b>10100 lm</b>	<b>17000 lm</b>	<b>23000 lm</b>
<b>Maximum light intensity:</b>	<b>1560 cd</b>	<b>2840 cd</b>	<b>4330 cd</b>	<b>6100 cd</b>	<b>7035 cd</b>
<b>Overall efficiency:</b>	<b>85 lm/W</b>	<b>110 lm/W</b>	<b>91 lm/W</b>	<b>91 lm/W</b>	<b>130 lm/W</b>

\* Test at 230Vac

### ACCESSORIES AVAILABLE / SPECIAL REQUESTS

Rated voltage: 12 Vdc (example code EWL-80/**12**)

Dimmer: (code EWL-80/**D**)

Different colour temperature (code EWL-80/**2700K**)

U bolt for pole mounting

Eyebolt

Special version for 12 Vdc, 24 Vdc, 48 Vdc applications with direct entry of the power cable in the lighting fixture (code EWL-80..**SB**)

# EWL series selection chart

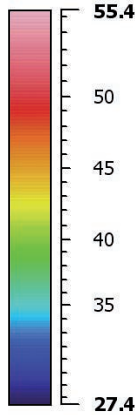
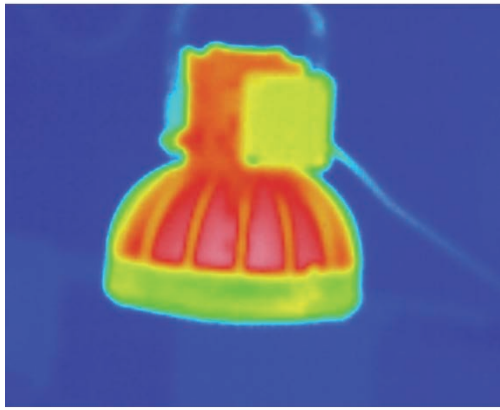

## THERMAL IMAGING

Following a very brief initial period, the lamp reaches thermal stability. This image shows the heat detected. With the ambient temperature at 28°C (as shown by the blue background) the LED lamp barely touches 56°C at the hottest point.

This thermal performance is tangible proof of the high efficiency of LED lamps as a source of light.

It is also worth noting the distribution of heat on the fins that are the result of sophisticated Thermal Management.

Code	Lamp Type	Dimensions mm		Class (+40°C)	Max Surface temperature °C (+40°C)	Class (+60°C)	Max Surface temperature °C (+60°C)	Weight kg	mm
		A	B						
EWL-70	LED	340	215	T6	65	T6	85	6,4	290x270x330
EWL-80	LED	343	260	T6	65	T6	85	8,6	290x270x330
EWL-801	LED	343	260	T6	80	T5	100	8,6	290x270x330
EWL-80C	LED	373	260	T6	65	T6	85	9,5	290x270x330
EWL-801C	LED	373	260	T6	80	T5	100	9,5	290x270x330
EWL-100	LED	484	385	T6	80	T5	100	19,4	420x410x560
EWL-1001	LED	484	385	T6	80	T5	100	19,6	420x410x560

## DIMENSIONAL DRAWING

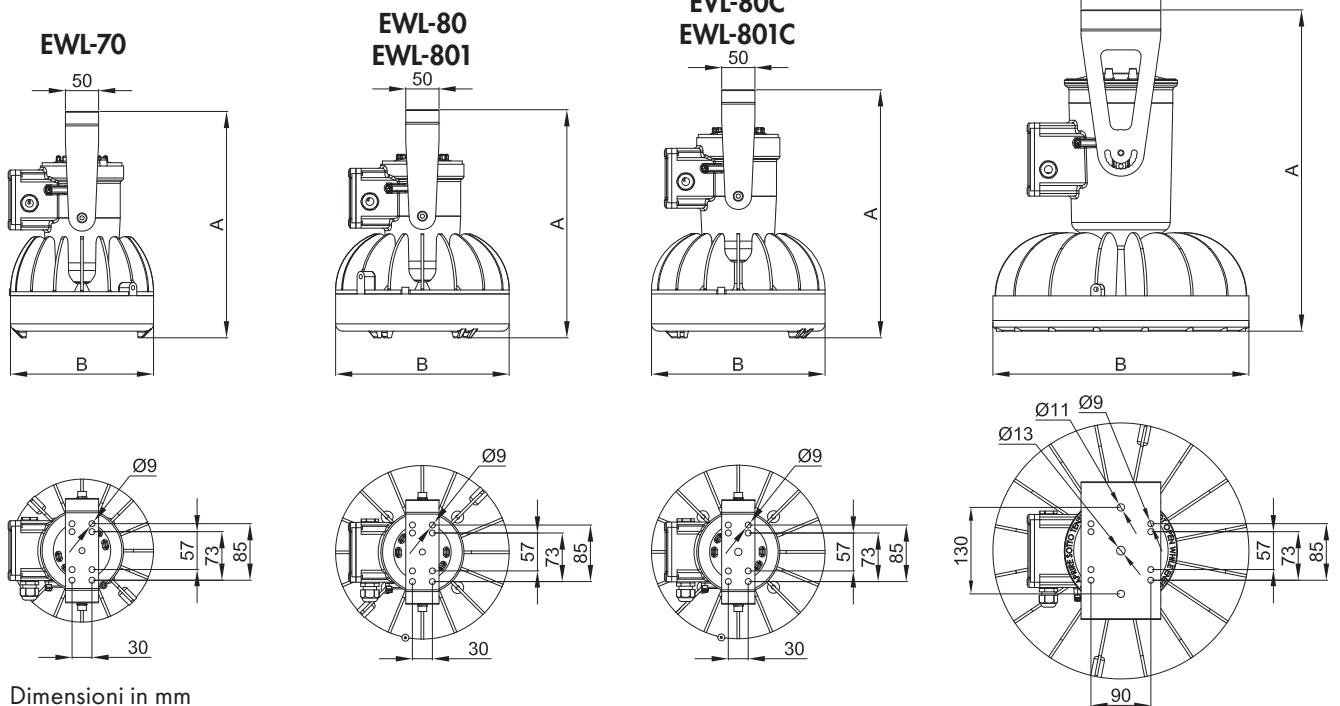

## DON'T FORGET TO ORDER THE ACCESSORIES

Example: Type of lighting fixture +  
EWL -80

UBD5G  
U bolt for pole mounting

+ other...see key



## EWL Accessories and spare parts available on request

ILLUSTRATION	DESCRIPTION	MODEL	FEATURES	CODE	KEY
	Pendant eyebolt	Ø interno 20	Material: galvanised steel	GOF-8	 
	U bolt for pole mounting	per pali Ø1 1/2"	Material: stainless steel 316L	UBD5S	 
	Supporting bracket	EWL-70 EWL-80...	Material: stainless steel 316L	G-750	
	Supporting bracket	EWL-100...	Material: stainless steel 316L	G-753	
	LED positioned on plate with electronic circuit	EWL-70	Plate material: IMS (insulated metal substrate)	G-659	
		EWL-80		G-747	
		EWL-80/24		G-667	
		EWL-100		G-748	
		EWL-100/24		G-688	
		EWL-1001		G-825	
	Cable gland	ISO M20	std. range cavo 6,3÷11,6	NAV20SIB	
	Power supply circuit	EWL-70	220 - 240 Vac	RV-40LED	
		EWL-80	120 - 240 Vac 120 - 370 Vdc 50-60 Hz	RSLD070-45	
		EWL-80/24	24 Vdc	RT-70LED	
		EWL-801	220 - 240 Vac	LEDDEVL80/2	
		EWL-100	100 - 240 Vac 120 - 370 Vdc 50-60 Hz	HLG-185H-C700B	
		EWL-100/24	24 Vdc	RT-240LED	
		EWL-1001	100 - 240 Vac 120 - 370 Vdc 50-60 Hz	HLG-185H-C700B	
	Front ring with glass	EWL-70...	Aluminium ring Borosilicate glass face	G70-0556	
		EWL-80...		G80-0556	
		EWL-100...		G100-0556	

# Installation and mounting methods

Example of pole mounting

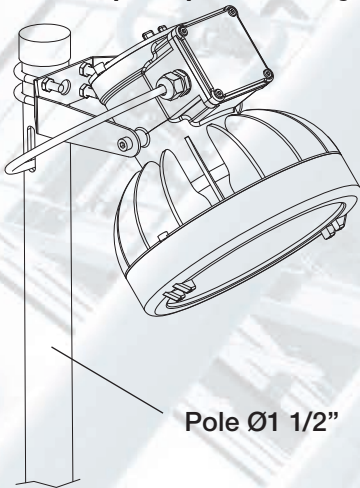

Example of wall mounting  
 $\beta$  angle from  $0^\circ$  to  $180^\circ$

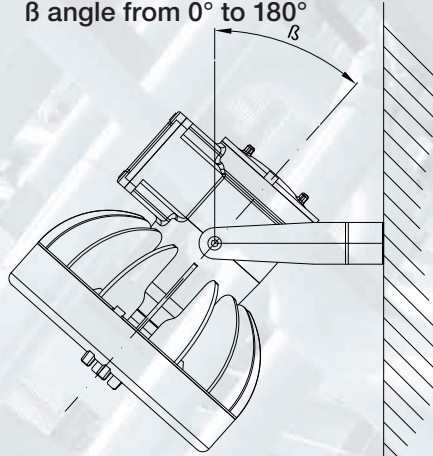

Example of pendant mounting  
 with eyebolt

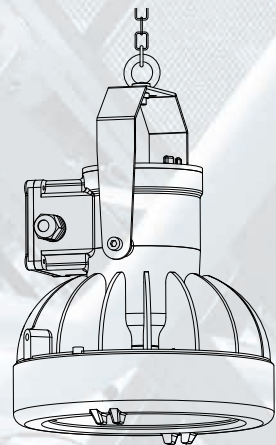

Special version for 12 Vdc\*, 24 Vdc, 48 Vdc (55W) applications with direct entry of the power cable in the lighting fixture (code EWL-80SB..., execution II 2GD Ex db op is IIC T.. Gb - Ex tb IIIC T..°C Db IP66)

Transportable version EWL-80SBTS..., complete with cable 8 meters long, sockets model PY216V and plug model SPY216V

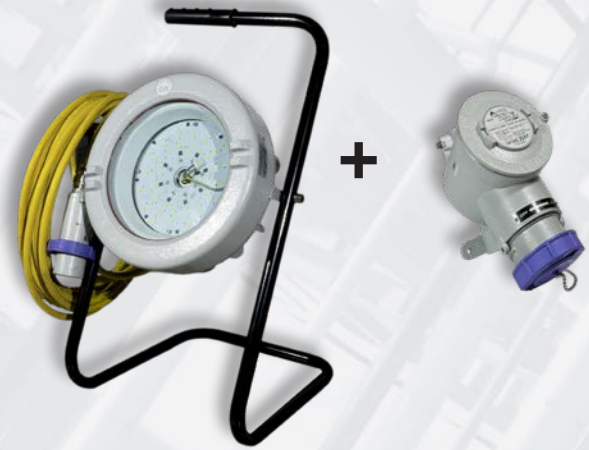

Order code:

EWL-80SB

**Power supply:**  
 12 = 12 Vdc\*  
 24 = 24 Vdc  
 48 = 48 Vdc

**Viewing angle:**  
 blank =  $120^\circ$   
 /10 =  $10^\circ$   
 /20 =  $20^\circ$   
 /40 =  $40^\circ$

\* On special request

Order code:

EWL-80SBTS

**Power supply:**  
 12 = 12 Vdc\*  
 24 = 24 Vdc  
 48 = 48 Vdc

**Viewing angle:**  
 blank =  $120^\circ$   
 /10 =  $10^\circ$   
 /20 =  $20^\circ$   
 /40 =  $40^\circ$









To order the transportable lighting fixture without socket and plug, omit the S in the code.

Example: **EWL-80SBT48/10**

\* On special request

# Features and photometric diagrams

## Example Peak Cd equivalents

				
EWL-70 (40W) EWL-80 (55W) EWL-801 (110W) EWL-100 (188W) EWL-1001 (177W) LED	(150W) (250W) (400W) (750W) - Mercury	(100W) (150W) (250W) (450W) (700W) Metal halide	(70W) (100W) (200W) (250W) (400W) Sodium	(320W) (500W) (1000W) (1500W) - Incandescent
Typical energy savings				

**EWL-70** illumination on the floor expressed in lux in a room 5m x 5m with the lighting fixtures centrally placed at **3.5m** in height

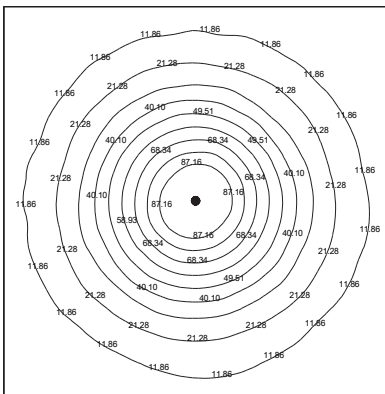

**EWL-80** illumination on the floor expressed in lux in a room 5m x 5m with the lighting fixtures centrally placed at **5m** in height

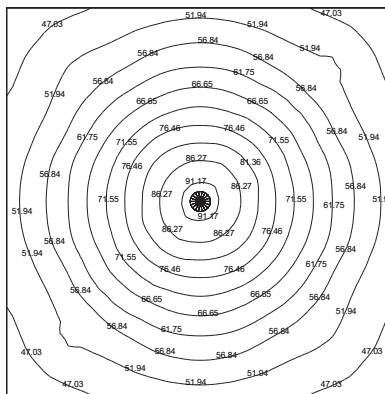

**EWL-100** illumination on the floor expressed in lux in a room 5m x 5m with the lighting fixtures centrally placed at **7m** in height.

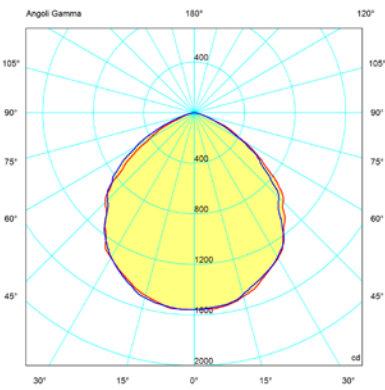
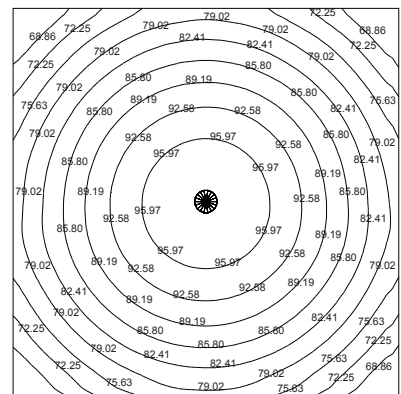

**EWL-70 Luminous flux: 3700 lm**

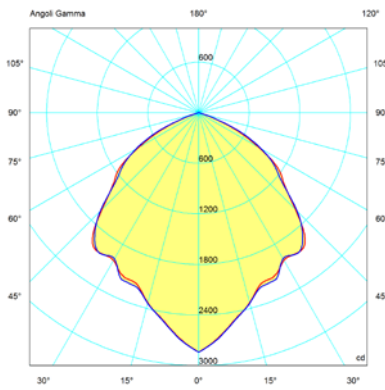

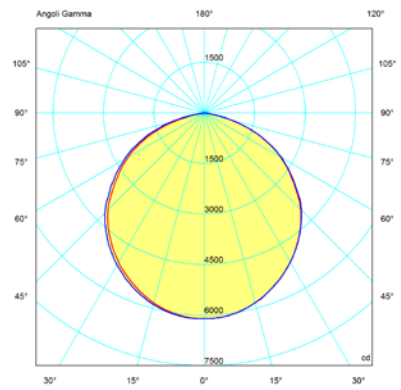

**EWL-80 e EWL-80SB...  
Luminous flux: 6050 lm**



**EWL-100 Luminous flux: 17000 lm**

On Cortem Group web site you can download .LDT and .IES lighting data files for the design and simulation of lighting levels in 2D and 3D, rendering and ray tracing.

-  = plane 90270
-  = plane 0180