

EXEL-L

- Complete with high efficiency LED strips
- Quick access to the internal electrical equipment
- Double locking system operated by hexagonal-head tool
- Zone 1, 2, 21, 22

'Ex op is'
safe optical radiation

Reinforced polyester resin body

Certified LED strips

Hinges

Detail of the internal side

Transparent polycarbonate cover



EXEL-L series lighting fixture with Cortem resin-bonded LED strips

EXEL-L series increased safety lighting fixtures for LEDs resin-bonded strips are suitable to be installed in hazardous areas where a high degree of protection and resistance against corrosion is required. EXEL-L series is GRP made and features the 'Ex de mb op is' according to the safe optical radiation standard. It's equipped with LED strips sealed in a transparent resin. The LED strips are manufactured by Cortem and they are certified and supplied along with the lighting fixture. The through wiring double ended makes installation on field easier and faster. The transparent cover is clipped into place on both sides of the fixture body with 8 clips on the EXEL-215L model and 14 clips on the EXEL-230L unit. This ensures excellent protection against dust and water over time. A safety switch housed inside the lighting fixture cuts off automatically the power supply when the lighting fixture is opened for the LED module and/or electrical component replacement. The EXEL-L series provides twelve models fitted with a Ni-Cd battery with electronic inverter for use in emergency operation. Thanks to the use of LED technology applied also on the emergency models, the operating time and the energy saving are considerably greater. A red LED warning light comes off if the battery needs to be replaced due to a short circuit or if the battery itself is dead.

Application sectors:

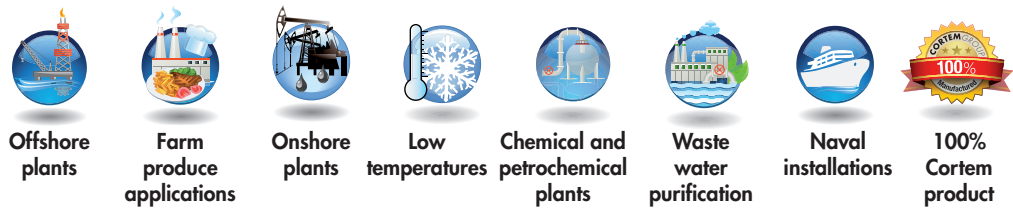

CERTIFICATION DATA

Classification:	Group	Category 2GD		
Installation: EN 60079.14	zone 1 - zone 2 (Gas)	zone 21 - zone 22 (Dust)		
Marking:	CE 0722 Ex II 2GD - Ex db eb mb op is IIC T6/T5 Gb Ex tb op is IIIC T...°C Db IP66			
Certification:	ATEX CML 15 ATEX 3188X			
	IEC Ex CML 15.0044X	All IEC Ex and INMETRO certification data can be downloaded at www.cortemgroup.com		
	INMETRO DNV 12.0055 X			
Standards:	CENELEC EN60079-0: 2012, EN60079-1: 2007, EN60079-7: 2007, EN60079-18: 2015, EN60079-28: 2015, EN60079-31: 2014 and EUROPEAN DIRECTIVE 2014/34/UE. IEC60079-0: 2011, IEC60079-1: 2007-04, IEC60079-18: 2014, IEC60079-28: 2015, IEC60079-31: 2013, IEC60079-7: 2006-07 European Directive 2004/108 Electromagnetic compatibility European Directive 2012/19/UE, 2002/96/CE, 2003/108/CE WEEE European Directive 2011/65/UE RoHS			
Class temperature:	85°C (T6)	100°C (T5)		
Ambient temperature:	-40°C +40°C (T6) -40°C +55°C (T5)	With emergency -20°C +50°C (T5)	Separate emergency -20°C +55°C (T5)	
Degree of protection:	IP66			

EXEL-L series lighting fixture with Cortem resin-bonded LED strips



EXEMPT FROM
PHOTOBIOLOGICAL RISK
(STANDARD IEC / EN 62471)



ORIGINAL PRODUCT

MECHANICAL FEATURES

Body:	Black shock and UV resistant fibreglass reinforced anti-static polyester resin
Diffuser:	Transparent polycarbonate, shock and UV resistant
Protected opening system:	Sliding system operated by a hexagonal-head tool (for safety reasons, the fixture can not be opened without the tool)
Gasket:	Acid/hydrocarbon resistant expanded silicone
Reclining frame:	Aluminium and stainless steel
Inner fixed frame:	Extruded aluminium
Bolts and screws:	Stainless steel
Entries:	4 x Ø25.5 entries (suitable for ISO M25x1.5 threads). Lighting fixture kit contains 3 model PLG21LXE7 plugs and 2 model NAVP251XE-X6DS cable glands for non-armoured cable
Mounting:	Nickel plated brass inserts with 2 x M8 holes

ELECTRICAL FEATURES

Ballast:	Electronic
Rated voltage:	110/277 Vac - 127/300 Vdc (EXEL-215L, EXEL-130L) 220/240 Vac/dc (EXEL-230L) 220/240 Vac (EXEL-115L)
Rated frequency:	50/60 Hz
Connection:	Directly to terminal board L, N, Pe section 4 mm ² terminal board with jumpers suitable for through wiring double ended
Emergency unit:	Electronic inverter 110/240 Vac 50/60 Hz, 110-270 Vdc. Batteries Ni/Cd, 4 Ah o 7 Ah, 6V
Wiring:	Silicone rubber cables with glass braid insulation for high temperatures

ACCESSORIES AVAILABLE / SPECIAL REQUESTS

Installation brackets

Grey polyester resin body (code EXEL-215LG)

Cable entry: 4 x Ø20.5 holes. Lighting fixture kit contains 3 model PLG11LXE7 plugs and 2 model NAVP201XE cable glands for non-armoured cable (code EXEL-215L/20)

Earthing continuity plates for metal cable glands

EXEL-L series lighting fixture with Cortem resin-bonded LED strips

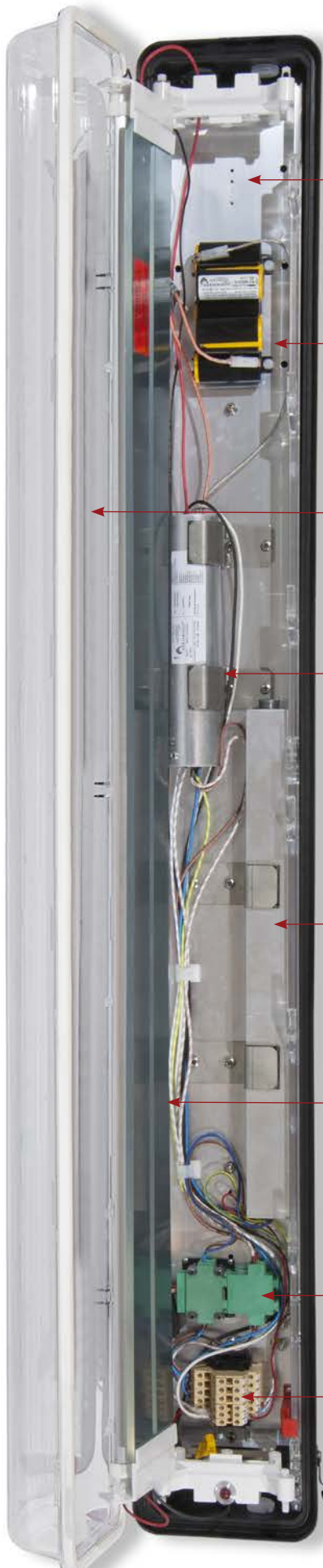

Inner fixed frame in extruded aluminium for components housing

Battery pack

Resin-bonded LED strips certified by Cortem
CE Ex II 2GD
Ex e mb IICT.. Gb
Ex mb IIIC T..°C Db IP6x

Certified electronic inverter housed in cylindrical aluminium box with one end sealed to allow passage of cables

Electronic ballast by Cortem according to:
EN 61347-1, EN 61347-2-13,
EN 62384, EN 61000-3-2,
EN 61000-4-5, EN 55015, EN 61547

Reclining frame in aluminium and stainless steel for LED tubes housing

Safety switch

Terminal board section 4 mm²

Quick access

Thanks to the new reclining frame on which the LED strips are housed, it's possible an easy access to the inside part of the lighting fixture. This system simplifies the maintenance and any interventions on the electrical part by the operator, ensuring greater safety and quick service

180° opening of the transparent diffuser by means of a hexagonal-head tool



Manually loosening the two screws, you can recline entirely the frame and access directly to the electrical components.



Internal electrical components easily accessible by the operator for a rapid replacement in case of fault. Wiring is carried out with safety and without that detached parts of the frame obstacle maintenance operations.

EXEL-L series lighting fixture with Cortem resin-bonded LED strips

Normal working

Code	Dimensions mm				Watt	LED strips n°	Power supply	Weight kg	 mm
	A	A1	B	C					
EXEL-115L	785	420	185	155	17	1	220-240 Vac 50/60Hz	4,9	195x155x820
EXEL-215L	785	420	185	155	29	2	110-277 Vac 50/60Hz 127- 300 Vdc	4,9	195x155x820
EXEL-130L	1370	720	185	155	29	1	110-277 Vac 50/60Hz 127- 300 Vdc	9,2	196x155x1400
EXEL-230L	1370	720	185	155	56	2	220-240 Vac/dc 50/60Hz	9,2	196x155x1400

Normal + emergency working

Code	Dimensions mm				Operating type	LED strips n°	Power supply	Watt	Discharge time in minutes	Weight kg	 mm
	A	A1	B	C							
EXEL-115LEF4..	785	420	185	155	normal + emergency	1	220-240 Vac 50/60Hz	17	180'	7,2	196x155x820
EXEL-215LEF4..	785	420	185	155	normal + emergency	2	110-240 Vac 50/60Hz 127-270 Vdc	29	180'	7,2	196x155x820
EXEL-130LEF4..	1370	720	185	155	normal + emergency	1	110-240 Vac 50/60Hz 127-270 Vdc	29	180'	10,1	196x155x1400
EXEL-230LEF4..	1370	720	185	155	normal + emergency	2	220-240 Vac/dc 50/60Hz	56	180'	10,1	196x155x1400
EXEL-115LEF7..	785	420	185	155	normal + emergency	1	220-240 Vac 50/60Hz	17	240'	7,2	196x155x820
EXEL-215LEF7..	785	420	185	155	normal + emergency	2	110-240 Vac 50/60Hz 127-270 Vdc	29	240'	7,2	196x155x820
EXEL-130LEF7..	1370	720	185	155	normal + emergency	1	110-240 Vac 50/60Hz 127-270 Vdc	29	240'	10,1	196x155x1400
EXEL-230LEF7..	1370	720	185	155	normal + emergency	2	220-240 Vac/dc 50/60Hz	56	240'	10,1	196x155x1400

Single and double lamp units with separate emergency battery pack for temperatures of -20°C to + 55°C example code EXEL-115LEF4E

Only emergency working

Code	Dimensions mm				Operating type	LED strips n°	Power supply	Discharge time in minutes	Weight kg	 mm
	A	A1	B	C						
EXEL-115LEE4..	785	420	185	155	only emergency	1	110-240 Vac \pm 10% 50/60Hz	180'	7,2	196x155x820
EXEL-130LEE4..	1370	720	185	155	only emergency	1	110-240 Vac/dc \pm 10% 50/60Hz	180'	10,1	196x155x1400
EXEL-115LEE7..	785	420	185	155	only emergency	1	110-240 Vac \pm 10% 50/60Hz	240'	7,2	196x155x820
EXEL-130LEE7..	1370	720	185	155	only emergency	1	110-240 Vac/dc \pm 10% 50/60Hz	240'	10,1	196x155x1400

Single and double lamp units with separate emergency battery pack for temperatures of -20°C to + 55°C example code EXEL-115LEE4E

EXEL-L series lighting fixture with Cortem resin-bonded LED strips

DIMENSIONAL DRAWING

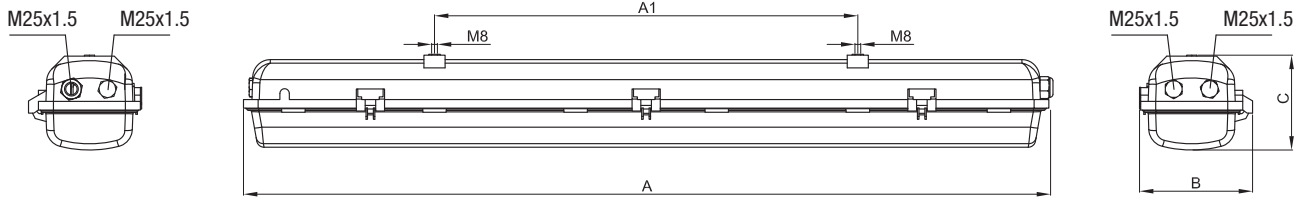

Single and double lamp units with separate emergency battery pack for temperatures of -20°C to + 55°C

Emergency lamp for temperatures of -20°C + 55°C

Batteries contained in a separate pack type SA141410/P in polyester resin.

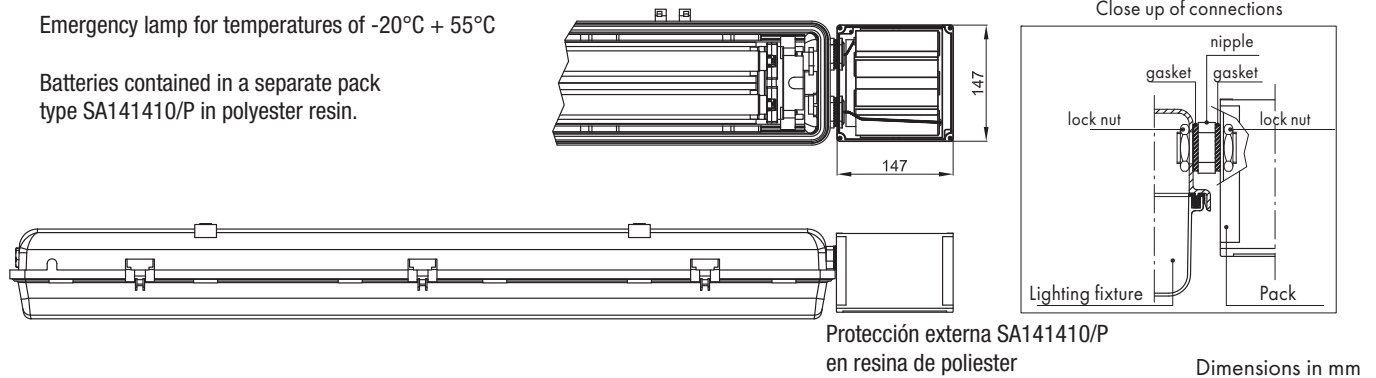

Dimensions in mm

DON'T FORGET TO ORDER THE ACCESSORIES

Example: Type of lighting fixture
EXEL-215L +

U bracket
G-0609

+ other ...see key

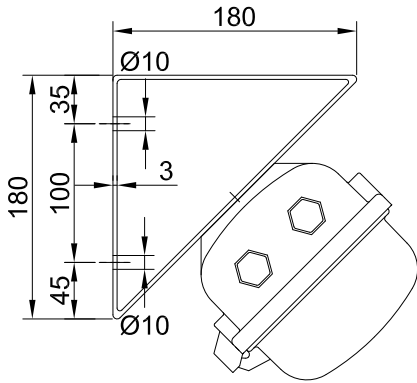

ILLUSTRATION	DESCRIPTION	MODEL	FEATURES	CODE	KEY
	Tige	Length: 250 mm	Material: stainless steel	BRF8MIN/250	
	Eyebolt		Material: galvanised steel	GOF-8	
	Type U bracket complete with screws		Material: bracket: galvanised steel screws: stainless steel	G-0609	
	Type V bracket complete with screws		Material: bracket: galvanised steel screws: stainless steel	G-0610	
	Type D bracket complete with screws		Material: bracket: galvanised steel screws: stainless steel	G-0611	

EXEL-L series lighting fixture with Cortem resin-bonded LED strips

ILLUSTRATION	DESCRIPTION	MODEL	FEATURES	CODE	KEY
	Type P bracket		Material: bracket: galvanised steel screws: stainless steel	G-0480	 
	LED resin-bonded module	EXEL-115L	LED strips exec. Ex mb	B115-0300/1	
		EXEL-215L		B215-0300/1	
		EXEL-130L		B130-0300/1	
		EXEL-230L		B230-0300/1	
	Transparent diffuser	EXEL-115L	Material: polycarbonate	B18-363	
		EXEL-215L		B36-363	
		EXEL-130L			
		EXEL-230L			
	Non-armoured cable gland complete with rubbers, seal and lock nut	ISO M25x1,5	Ex e II IP 66/67 (std. range cavo 10-18)	NAVP25IXE-X6DS	
	Plug with seal and lock nut	ISO M25x1,5	Ex e II IP 66/67	PLG2ILXE7	
	Hexagonal-head tool	Hexagon 10		CLAFT10	
	Electronic inverter		110-240 Vac, 110-270 Vdc	EI-30L/2	
	Battery pack		4 Ah 6V NiCd 7 Ah 6V NiCd	G-0309B G-0309	
	Electronic ballast	EXEL-115L	220/240 Vac 50/60Hz	EB115L	
		EXEL-215L EXEL-130L	100/277 Vac 50/60 Hz 127/300 Vdc	EB215L	
	Electronic ballast	EXEL-230L	220/240 Vac/dc 50/60 Hz	EBL3040-1-90/1	
	Earthing continuity plates for metal cable glands	Holes M25x1.5	Material: brass	B-479	
		Holes M20x1.5		B-479/1	

EXEL-L series lighting fixture with Cortem resin-bonded LED strips



45° angle mounting
TYPE "D"

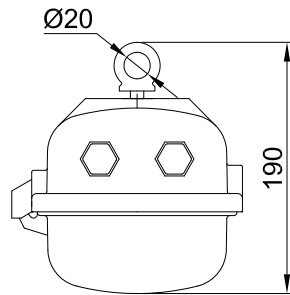

Pendant mounting
with eyebolt TYPE "O"

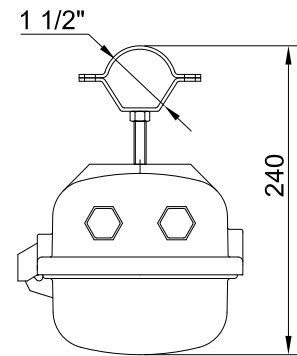

Mounting using 1.1/2"
metal clamps TYPE "P"

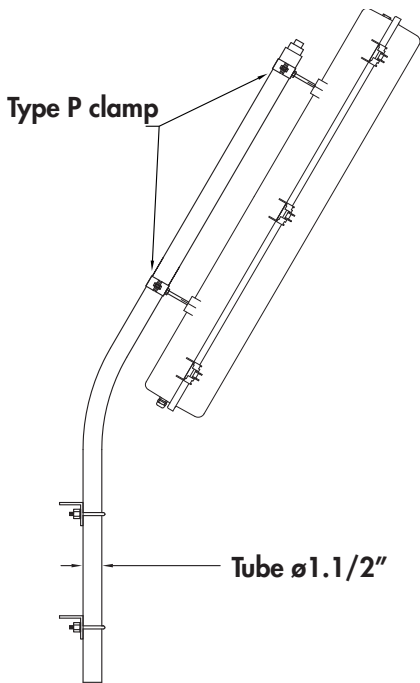

Standard pole mounting

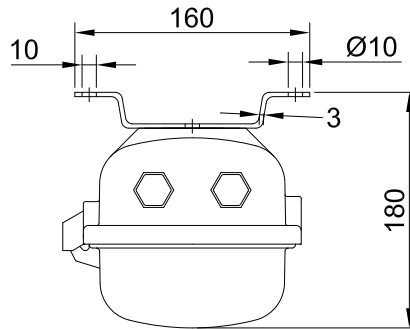

Low ceiling mounting with
clamp TYPE "U"

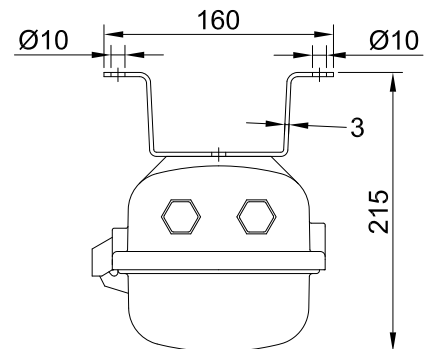

High ceiling mounting with
clamp TYPE "V"

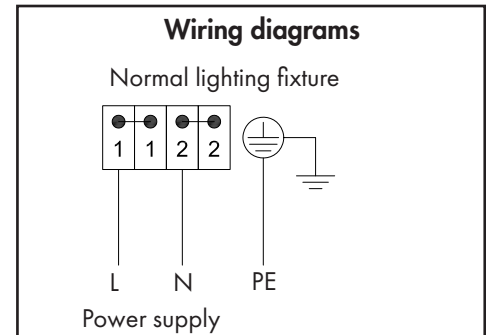

Connections can be made on either side of the fixture body
for simple, fast installation

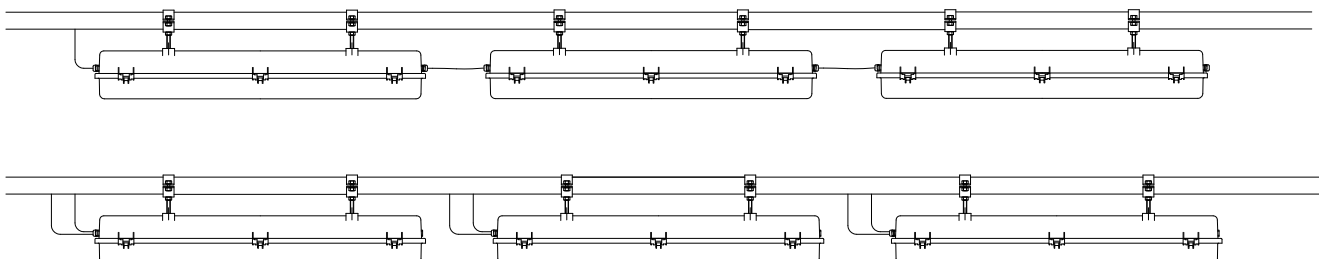

EXEL-L series lighting fixture with Cortem resin-bonded LED strips

Electrical features	EXEL-115L	EXEL-215L	EXEL-130L	EXEL-230L
Power supply:	220-240 Vac	110-277 Vac/dc	110-277 Vac/dc	220-240 Vac/dc
Rated frequency:	50-60 Hz	50-60 Hz	50-60 Hz	50-60 Hz
Power consumption:	17 W	29 W	29 W	56 W
Connection:	Direct connection to terminal board L, N, Pe. Section 4mm ² , suitable for loop-in/loop-out			
Power factor:	>0,94 *	>0,93 *	>0,93 *	>0,98 *
Rated current:	81 mA*	146 mA*	146 mA*	265 mA*
EMC (electromagnetic compatibility):	EN 55015, EN 61547, IEC 61000-3-2, IEC 61000-3-3			
THD (total harmonic distortion):	<4% 230 Vac, 50 Hz			
Over-voltage protection:	4 kV	4 kV	4 kV	4 kV
Driver performances:	Over-Voltage protection, Over-Current protection, Short-Circuit protection			
Photometric features				
LED:	Resin-bonded LED strips			
Viewing angle:	120°	120°	120°	120°
LED Colour temperature:	5000 K	5000 K	5000 K	5000 K
CRI:	80	80	80	80
Instant Restrike:	SI	YES	SI	YES
Lumen:	1426 lm	2850 lm	2817 lm	5637 lm
Maximum light intensity:	464 cd	927 cd	960 cd	1920 cd
Overall efficiency:	84 lm/W	98 lm/W	98 lm/W	100 lm/W

* Test at 220Vac

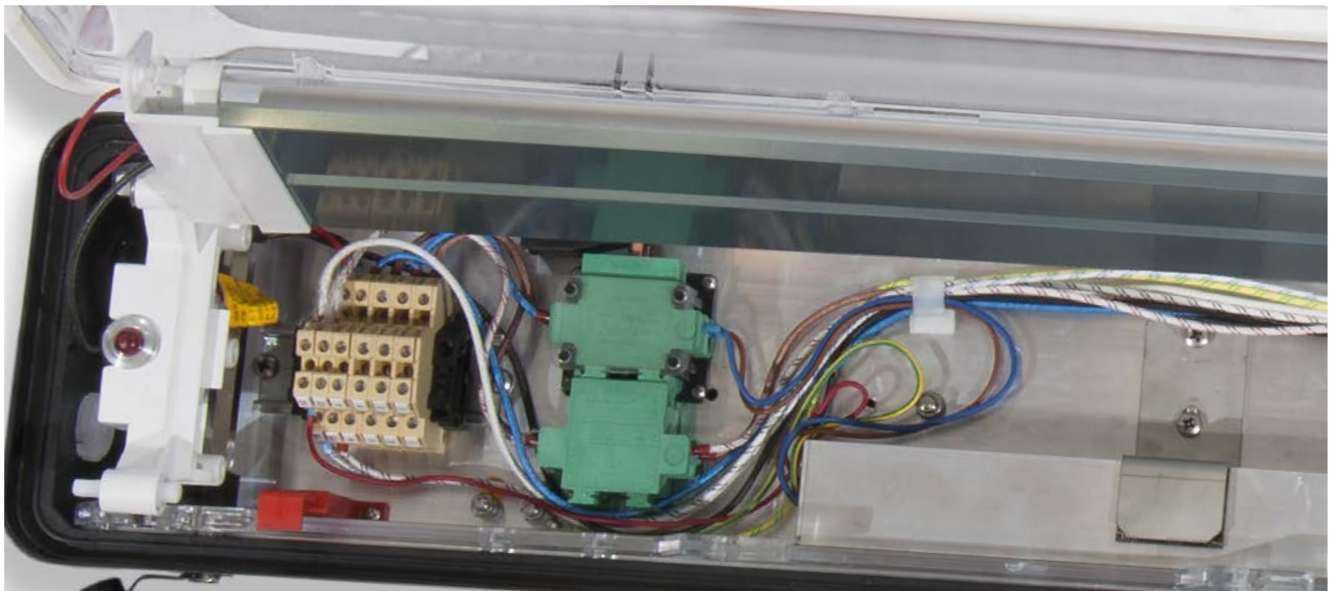

EXEL-L series lighting fixture with Cortem resin-bonded LED strips

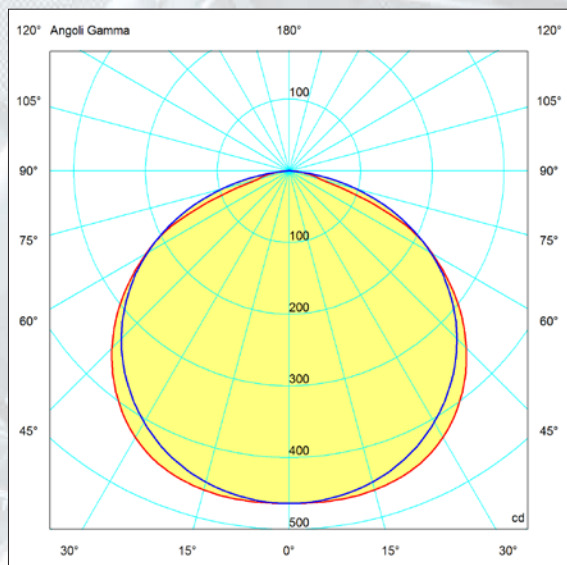

EXEL-115L

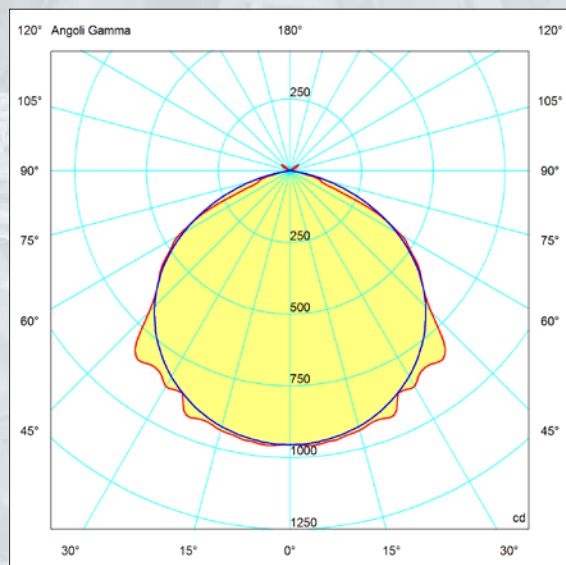

EXEL-130L

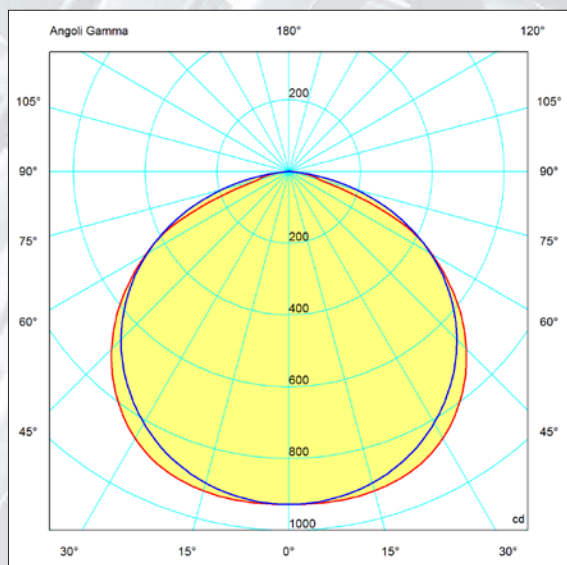

EXEL-215L

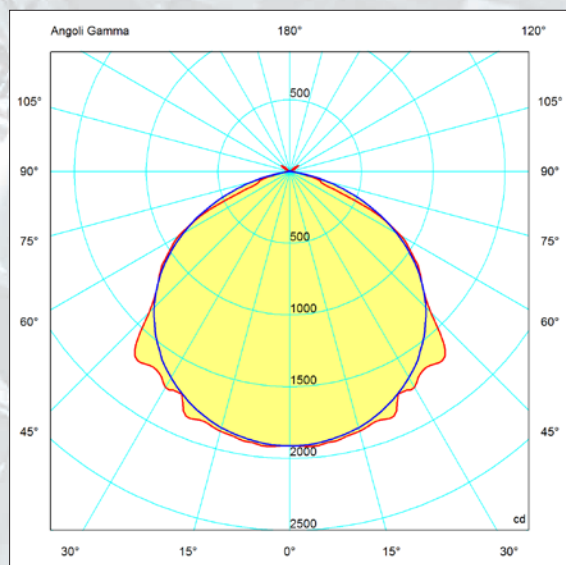

EXEL-230L

On Cortem Group web site you can download .LDT and .IES lighting data files for the design and simulation of lighting levels in 2D and 3D, rendering and ray tracing.

— = plane 90270
 — = plane 0180